

[Clutches]



[The range of clutches from Densitron is based on the wrap spring principle. Wrap spring clutches are compact and highly efficient power transmission devices for engaging and disengaging drive to rotating components. As a control device, the clutch is able to control the application of far greater power than a direct actuator of comparable size.

The addition of friction brakes and an indexing feature incorporated in new devices in this range, extend the potential of the clutch to many new applications where solenoid or motor actuators were previously preferred.]



High Power Density

(Reduce packaging problems in compact machinery)

[The compact clutch is a control device for engaging/disengaging rotating drive to a machine axis. When disengaged, the input and output of the clutch turn independently of one another and of the clutch case. When energised, the input and output are connected and the driving axis is coupled to the driven clutch plate.

By comparison with a motor, the clutch has extremely high power density as a control device and is physically much smaller than a motor capable of producing comparable torque. The photograph compares the EC25 clutch to a size 34 stepping motor with similar torque capability.

An illustration of a clutch used to drive a rotary cutting mechanism is shown, drawn to the same scale. The clutch shown produces more than 20 times as much torque as the solenoid mechanism over an unlimited operating angle in this application.]



EC25 clutch compared to larger size 34 stepper with comparable torque.



Decouple Drive Inertia

(Much higher acceleration/deceleration than motor solutions)

[The drive motor runs continuously. Only the inertia of the driven axis has to be started/stopped. This reduced inertia of driven load further assists extremely fast acceleration.]

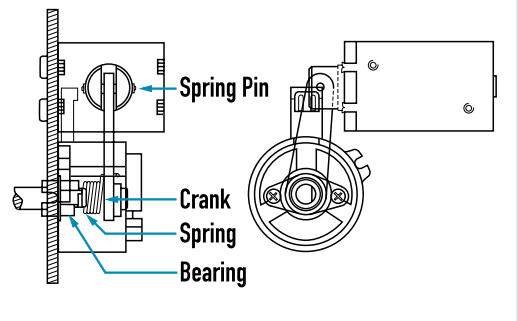

[Clutches]

Make Use of Free Power Sources

(Eliminate motors and reduce electrical power)

[In some applications, a primary drive other than a motor may be freely available; this might be an internal combustion engine in a vehicular environment, or manual operation (by key or handwheel). Using a clutch to engage or disengage drive can allow use of such power sources with minimum electrical power drain. An example of the indexing clutch used in a doorlock application is shown.]



Multiple Axis Drive

(Reduced multiple motors and system costs)

[In many machines, higher torque is needed for starting and accelerating each axis than to maintain it at running speed. Where each axis is individually driven, the drive motors must each be able to meet the peak torque of its load axis. The use of clutches may allow reduction of the total power required. To explain this point more clearly, consider the example of a 4-axis machine as shown.]

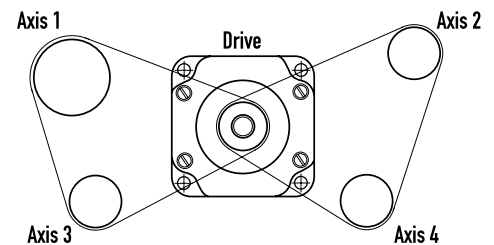

Axis	Speed (RPM)	Running G Torque (Nm)	Peak Torque (Nm)	Power (Peak) Watts	Drive Engagement Conditions
Axis 1	300	2	6	63 (189)	Never concurrent with Axis 3
Axis 2	450	1.5	4	71 (189)	Never engages concurrent with Axis 4, independent running
Axis 3	450	2	6	95 (284)	Never concurrent with Axis 1
Axis 4	450	4	6	190 (284)	Never engages concurrent with another axis, independent running

[The maximum running power is the sum of Axis 2, Axis 4, plus the larger of Axis 1 and Axis 3, in this case this would be 356W. The maximum peak power is the larger of (Axis 4 peak plus Axis 2 running, plus the larger of Axis 1 or 3 running) or (Axis 4 running plus Axis 2 peak plus the larger of Axis 1 or 3 peak), in this case power would be 663W.]

[Clutches]



[A single drive motor rated for 356W and 663W peak is sufficient in a clutch based system. It may be of further benefit that high drive inertia is beneficial to speed stability, this may allow a comparatively inexpensive induction motor to be used as the primary drive. When engaged all machine axes are effectively synchronised to this primary drive. Where independent motors are used for each axis, total motor capacity of 419W continuous and 946W peak is required. For fast acceleration low inertia, rare-earth magnet motors may be required. Overall cost is likely to be much higher than in the clutch based drive system.

The power and cost benefits of using clutches in a multi-axis system become greater as the number of controlled axes increases, and as drive to different machine axes becomes more exclusive (i.e. as a larger proportion of the machine is expected to be idle at any given time.)



Description of Operation

[The housing and coil assembly remain stationary and do not rotate during clutch operation. When the coil is energised, the control ring is attracted by the magnetic flux to the shoulder. The friction between these drags the control ring around with the turning shaft, causing the wrap-spring coils to tighten down and grip the Wrap Hub. Torque is then transmitted from input to output side of the clutch. The basic EC series clutch is uni-directional and transmits torque in only one direction of rotation. Bi-directional types can be supplied to special order.

The construction of the basic wrap spring clutch of EC series is illustrated below.]

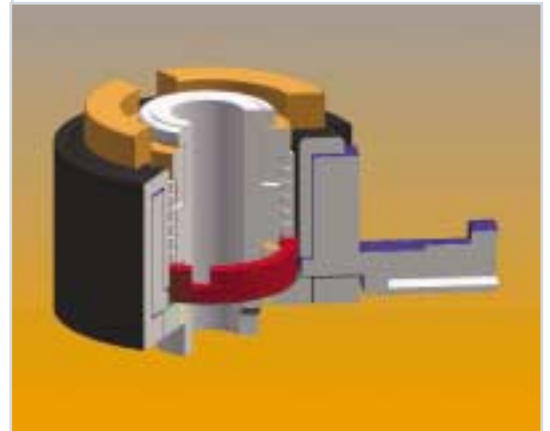
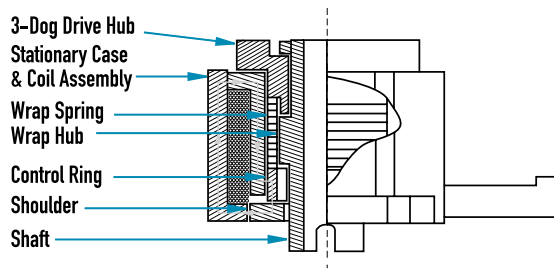

Cross-section of EC series clutch.

Clutch-brake Units

(Fast stopping of low friction loads)

The EC20CB-LL clutch-brake unit combines the function of the EC20 clutch with a friction brake. When energised, the brake disengages and the clutch engages, behaving as the standard EC20 clutch. On disengagement, a friction brake is applied to the output end to bring the load to a stop more quickly and/or hold it in position.

Clutch-brake units are generally required when the load is required to be stopped or held in position when drive is disengaged and where the load has insufficient friction to stop on its own accord.

The clutch-brake unit EC20CB-LL is illustrated below. The anti-rotation tang is part of the friction-brake; this must be retained to prevent rotation, normally this is held in the same feature which holds the connector to prevent rotation of the clutch body.

EC75

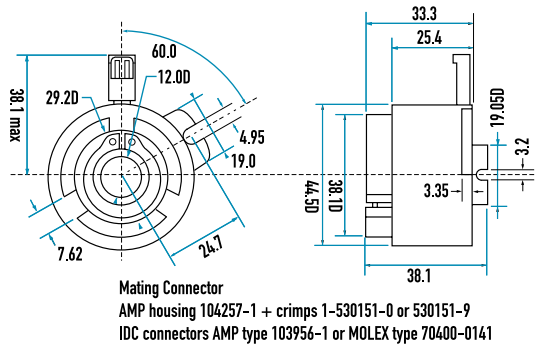

EC5/20/30

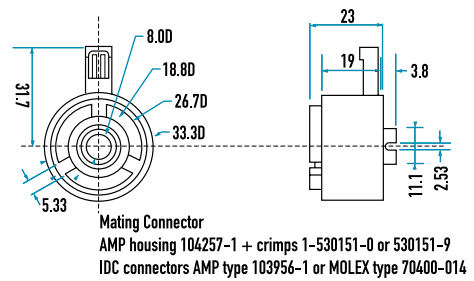

EC15/25

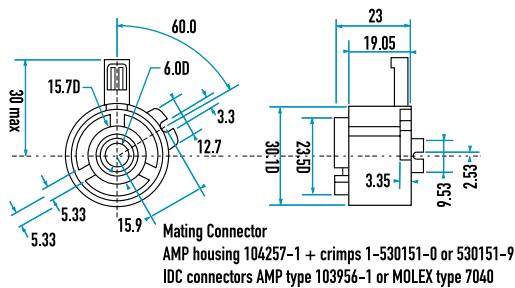

EC20CB-LL

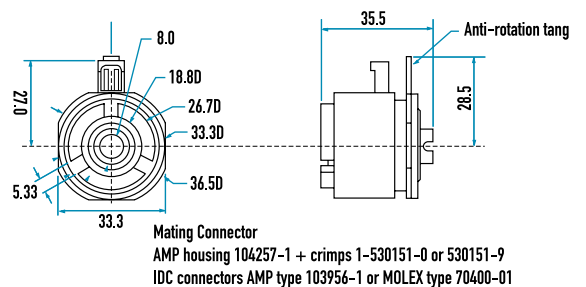

EC & ED Series Wrap Spring Clutches



The EC and ED series wrap spring clutches are the basic series, these are free running in the de-energised state in either direction. In the energised state they transmit torque in one direction, and are free running (with a small friction drag between input and output) in the other direction. The EC type is illustrated. The ED type clutches are similar, except in that drive to the shaft is by a flat (D-cut) rather than by a cross pin as used in the EC type. Details of ED types are available on request.

Electrical termination is by a two pin connector as standard. Termination by flying leads is available on request.

The EC25 and EC75 are high performance clutches with consistently fast engagement and disengagement over longest possible working life. These are recommended for arduous applications.

The EC15, EC20 and EC30 are economy models offering good performance at a highly competitive price.

The new EC5 clutch uses a plastic spring to give lowest possible cost while retaining excellent performance and reliability characteristics, provided the reduced torque is sufficient for the application.

Standard coil options are 12V or 24V (and 90V for the EC75) operation. Other coil voltages can be produced to customer requirements, provided volumes are sufficient.

To assist in mechanical interface to the clutches, an adaptor is available to mate with the 3-dog hub. This incorporates an 'Oilite' type bush to allow free running on a metal shaft - the shaft should be finished appropriately if free running is required.

Specifications

[Coil parameters and available options for EC series clutches are given below.]

Part No. (Torque)	Rotating Direction	Bore (Pin Size)			Coil Rating (Power)
EC5 5lb-in/0.57Nm	CW or CCW	1/4" (3/32") 6mm (2.5mm)	5/16" (3/32") 8mm (2.5mm)		12V (3.5W) 24V (3.5W)
EC15 15lb-in/1.7Nm	CW or CCW	1/4" (3/32") 6mm (2.5mm)	8mm (2.5mm)		12V (2.5W) 24V (2.5W)
EC20 20lb-in/2.2Nm	CW or CCW	5/16" (3/32") 6mm (2.5mm)	8mm (2.5mm)		12V (3.5W) 24V (3.5W)
EC25 25lb-in/2.8Nm	CW or CCW	1/4" (3/32") 6mm (2.5mm)			12V (3.5W) 24V (2.5W)
EC30 30lb-in/3.4Nm	CW or CCW	5/16" (3/32") 6mm (2.5mm)	8mm (2.5mm)		12V (3.5W) 24V (3.5W)
EC75 75lb-in/8.5Nm	CW or CCW	3/8" (1/8") 10mm (3mm)	1/2" (1/8") 12mm (3mm)	5/8" (1/8") 15mm (3mm)	12V (6W) 24V (6W) 90V (6W)
EC20CB-LL 20lb-in/2.2Nm	CW or CCW	8mm (3mm) 6mm (2.5mm)			12V/24V 24V (3.5W)

[Clutches]

Slipper Mechanism

(Limits torque applied to clutch drive)

Where a clutch is used with a high inertia load, high transient loads can be applied when the load is engaged due to rapid acceleration. A slipping device is available which limits the maximum torque applied to the clutch, this should be used with high inertia loads to prevent instantaneous overload from being applied. The slipper device will slip at a preset torque rating to limit the maximum load applied to the clutch.

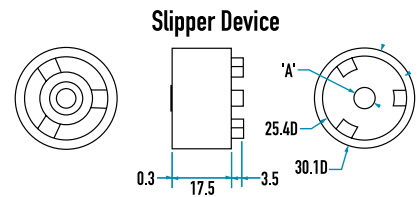

Accessories

(Limits torque applied to clutch drive)

To assist in mechanical and electrical interface to the clutches, a 3-dog adaptor to engage with the clutch drive plate and leadsets for electrical connection are available. P/N 1215 001 is 2-wire leadset. Leads are 24 AWG, 381mm long.

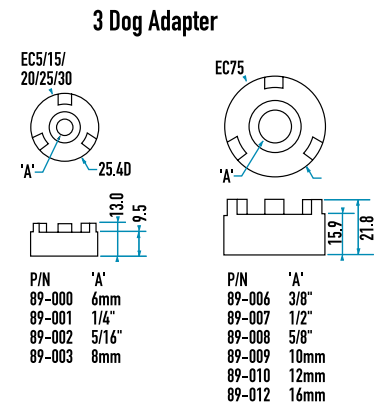

Clutch Performance Information

- T.T.E.** Time-to-engage: Time for magnetic flux build up in clutch to activate the control ring and wrap spring.
- T.T.S.** Time-to-speed: T.T.E. + the time for the system to accelerate.
- T.T.D.** Time-to-disengage: Time for magnetic flux to decay and the spring to unwrap.
- T.T.Z.** Time-to-zero: T.T.D. + deceleration time of the system

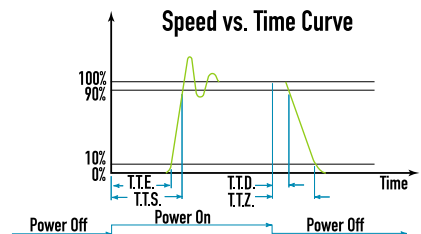

Time to Engage

Time-to-engage is directly related to the input speed. The higher the input speed, the quicker the clutch will engage. For a given input speed, response time will fall in the tinted region. The black lines represent the operating range.

The time for the clutch to engage varies from cycle-to-cycle. To determine this variation, see example.

Example: The EC25 clutch at 500rpm has a maximum cycle-to-cycle response time variation of plus or minus 1.5 milliseconds.

[Clutches]

Estimated EC15 and EC20 Performance

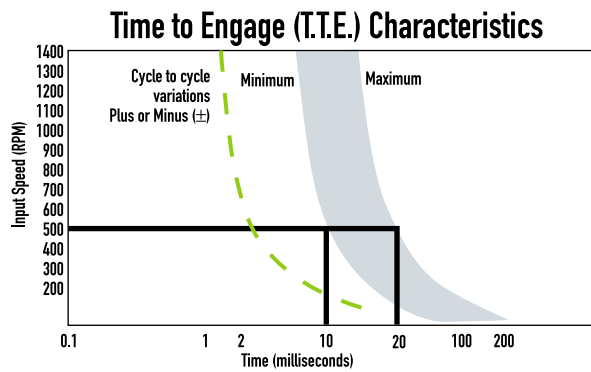

Example: The EC15 clutch at 500 rpm has a response time of between 9 and 30 milliseconds.

Estimated EC25 and EC75 Performance

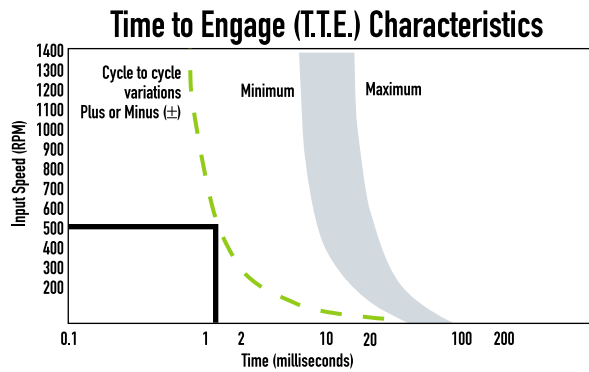

Estimated EC5 Performance

