

[Holding Magnets]

●●● Holding Magnets

Holding Magnets develop high attraction forces to flat magnetic materials. They are used to pick up or hold magnetic materials, and find application in applications ranging from holding of ferromagnetic workpieces during machining or assembly operations, through door latching or holdback devices, to selector devices in textiles machinery. There are three main variants of these devices

HM (Holding Magnet) devices comprise of a permanent magnet usually in the form of a disc, encased in a mild steel pot which provides a return flux path. A strong magnetic field flows when the device is placed in contact with a ferromagnetic surface, developing a powerful attracting force to the surface.

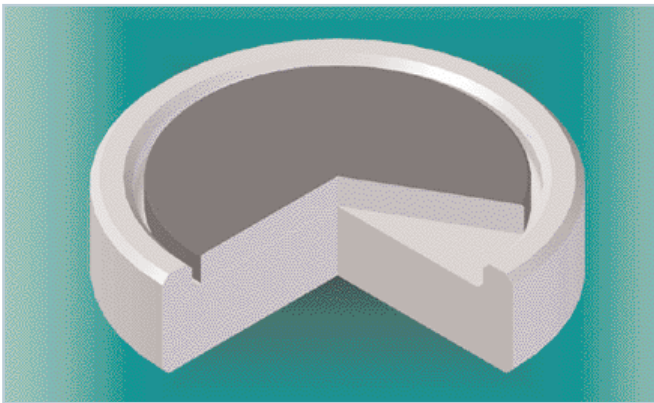

EM (ElectroMagnet) devices comprise a magnetic armature, usually in the form of a mild steel pot, into which a coil is fitted, such that magnetic flux flows when the coil is energised. The flux path contains an airgap designed such that when placed against a flat ferromagnetic surface, the airgap is closed by the mating part and flux flows between electromagnet and surface developing a powerful attraction force. The flux can be turned off by removing power from the coil, allowing a held part to be released. When power is removed some residual magnetism will remain, this is usually less than 5% of the 'ON' force, if this is a problem a spring loaded ejector pin can be incorporated in the part to ensure

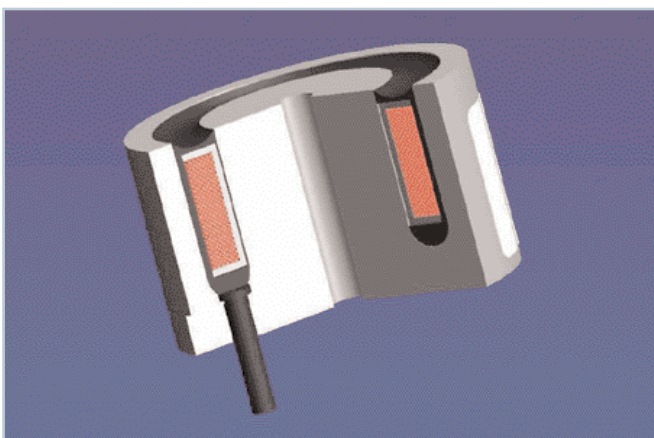

complete release. EM devices are often used as door holdback devices in large buildings, personnel can walk through the building unimpeded, if a fire alarm is triggered, or power fails, the doors are released to shut off airflow through the building. Due to the near-zero airgap, a high flux and force can be developed with minimal electrical power applied, special devices can be used as shut-off devices for gas-fired systems where power to stay open is derived from a thermocouple.

HMER (Holding Magnet Electrical Release) devices combine the functions of the above devices. A permanent magnet is mounted underneath a 'leakage pole' around which a coil is wound. The magnet drives flux around the magnetic path with no electrical power applied to develop a strong holding force to a ferromagnetic surface. To 'turn off' the attraction force, the coil is energised so as to drive flux in the reverse direction. Flux due to the permanent magnet is diverted to flow around a secondary path between the leakage pole and case of the device. Cancellation of the magnetic flux is not perfect, so an ejector pin is usually fitted to these devices to overcome any residual force and ensure release. As the release pulse only needs to be applied instantaneously energy requirement can be very low, applications include shutter release mechanisms, selector mechanisms for textiles machinery, work holding fixtures, and trip mechanisms for earth leakage circuit breakers.

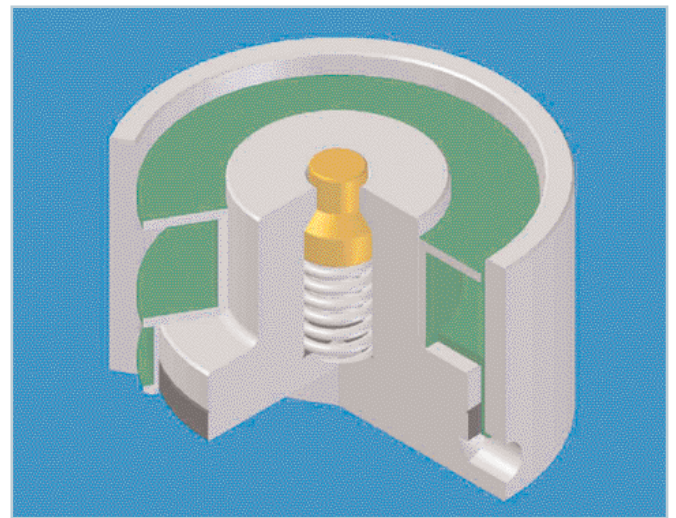

Armature Plates - All standard holding magnet devices are designed to work against a flat ground ferromagnetic surface with surface treatment no more than 15 microns thick. Irregularity of the surface, or thick non-magnetic surface treatment will impair the efficiency of the device and reduce achievable holding force. If there are compelling reasons that a larger airgap must be present in the system, a modified design with larger magnets or modified polepiece design may be required to achieve optimum force and

[Holding Magnets]

efficiency. Geeplus offers armature plates to work with our range of holding magnet devices, these armature plates are machined to a very flat finish, and are finished with a thin coating of electroless nickel. The stud mounting permits use with an ejector pin.

Residual Magnetism – when excitation to an electromagnet is turned off, some residual field will remain in the system due to residual magnetism. In order to minimise this, both the electromagnet case, and the armature plate should be made of low carbon steel of an appropriate grade. Magnetic properties are degraded by machining,

so all steel components used in holding magnets and armature plates are subject to magnetic anneal in hydrogen to restore optimum magnetic properties. In applications where residual magnetism when an electromagnet is switched 'OFF' is a problem, an ejector pin can be fitted to the centre of the device. This is a spring-loaded pin which protrudes a small distance from the face of the polepiece in the extended position, and which has a spring force sufficient to overcome the force due to residual magnetism. When an ejector pin is fitted, the developed holding force will be reduced by the spring force.

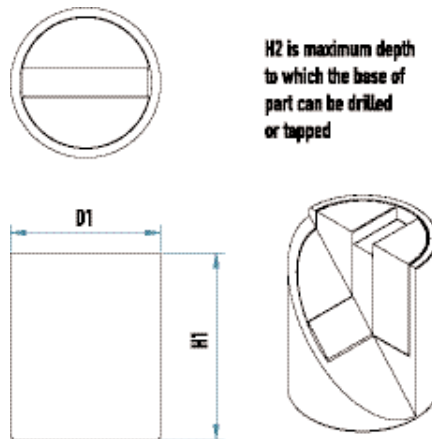

Part Number	D1	H1	H2	F(N)
SMPD 00100	6	20	10	6
SMPD 00101	8	20	10	10
SMPD 00102	10	20	8	40
SMPD 00103	13	20	6	60
SMPD 00104	16	20	2	125
SMPD 00163	20	25	5	250
SMPD 00105	25	35	7	400
SMPD 00164	32	40	5	600

[Electromagnets]

Electromagnets

General Specifications

- The hot condition is steady temperature achieved at rated voltage in still air with constant voltage excitation at rated voltage.
- When de-energised some residual force will remain at a maximum of 5% of the specified holding force.
- Standard finish is nickel plating.
- Termination is by leadwires 300mm long.
- All Electromagnets are with flexible grommets to allow them to be either side or base exit.

Examples of P/N construction are as follows:

Size Voltage
EM 0025 - 12

Type	EM0025	EM0032	EM0040	EM0050	EM0080
Power Consumption (W)	3.0	4.0	5.5	6.0	12.5
Holding Force @ 20°C (N)	150	280	500	750	2100
Holding Force HOT (N)	140	250	450	660	1800

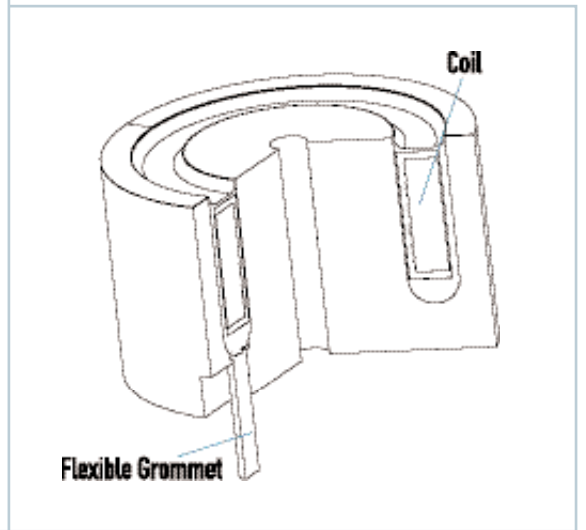
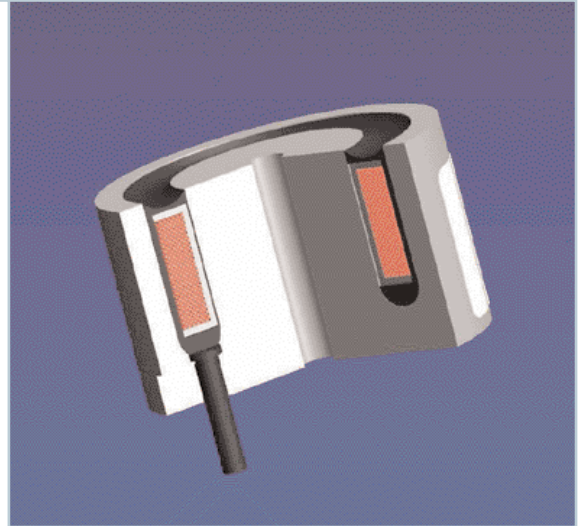

Armature Plates

P/N	Ø DI (+/- 0.2MM)	T(+/-1.2MM)	L(+/-1.2MM)	Thread	Use With
AP27	27	4	18	M4 x P0.7	EM0025
AP34	34	5	18	M4 x P0.7	EM0032
AP42	42	5	20	M6 x P1.0	EM0040
AP52	52	6	20	M6 x P1.0	EM0050
AP82	82	8	25	M8 x P1.25	EM0080

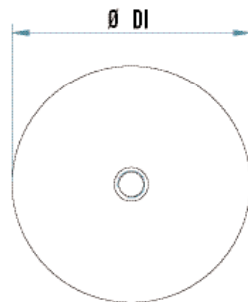
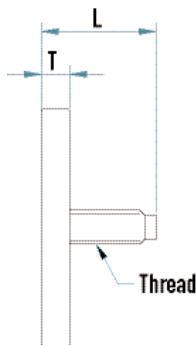

•••

EM0025-XX

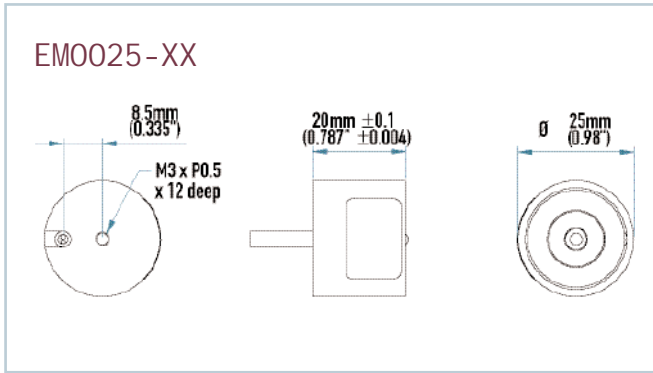

EM0032-XX

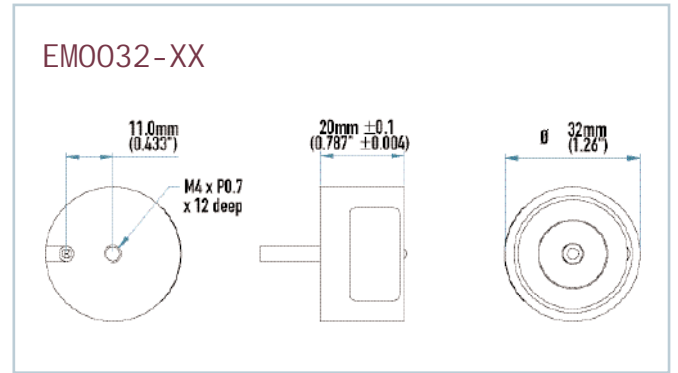

•••

EM0040-XX

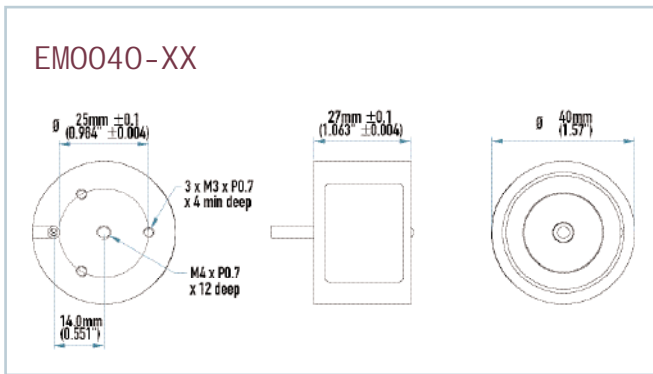

•••

EM0050-XX

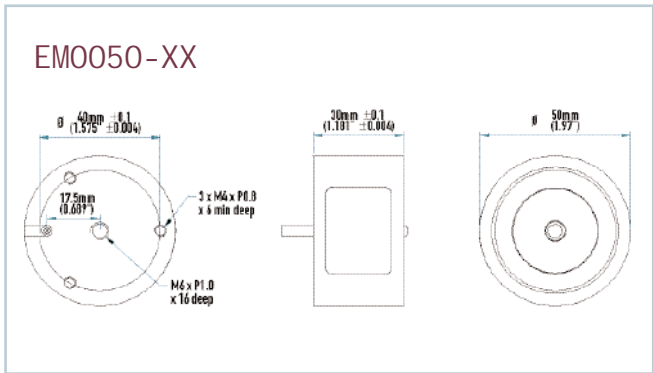

EM0080-XX

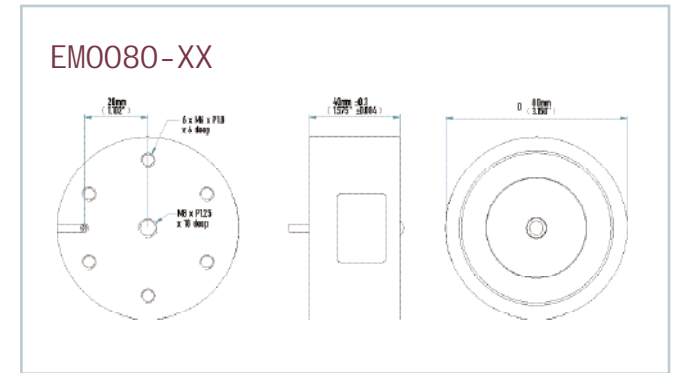

•••

HMER40

